



Hold the Salt, Please

Is Desalination a Viable Answer to America's Potential Water Crisis?

By Geoff Bilau

Residents of drought-stricken communities in the South didn't need a government report to tell them the nation faces a potentially crippling water shortage within the next five years. They're already learning to cope with restrictions and rationing in order to preserve what little water remains at their disposal.

For many other parts of the nation, however, an EPA projection that at least 36 states will experience some kind of water shortage by 2012 arrives as a wake up call to find solutions — and fast.

The causes are numerous, ranging from weather and climate change to simple population growth and wasteful usage. But the solutions are not so easily determined. While conservation and recycling are central to the fight, there's no changing the fact there is only so much freshwater available, and at current usage levels it's no longer enough to go around.

One way to change that perception that is gaining a great deal of steam in the United States and worldwide is desalination, the process of essentially removing the salt from sea or brackish water and creating potable water.

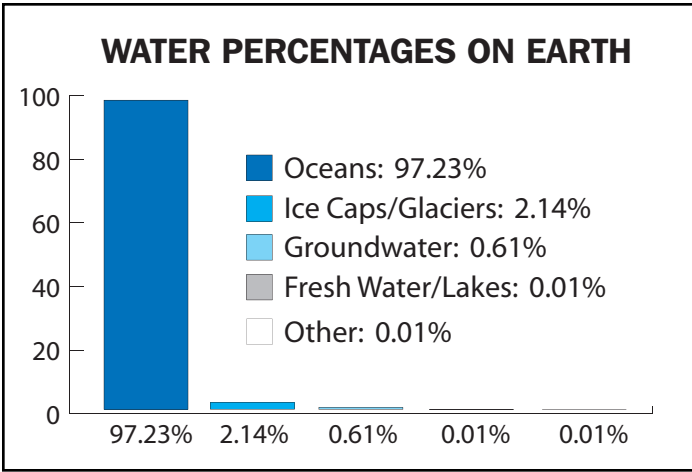

And while the science itself dates back to ancient mariners boiling seawater and turning the steam into drinking water (known as distillation), newer technologies are offering great promise of contributing as much as 10-15 percent of the world's freshwater. The U.S. Geological Survey (USGS) estimates more than \$70 billion will be spent worldwide by 2022 to study, design and build new desalination facilities.

HOW DOES IT WORK?

The majority of modern day desalination uses a method called reverse osmosis, where water with a salinity exceeding drinkable levels is forced at great pressure through semi-permeable microscopic membranes that filter out salt and other contaminants. The process produces on average about 15 to 50 gallons of fresh water for every 100 gallons of salt water pushed through the membranes.

Ocean water contains about 35,000 parts per million (ppm) of salt. To be considered safe for drinking water, the salinity must be reduced to around 1000 ppm (the voluntary EPA standard is 500 ppm.) For crop irrigation purposes, the required level is less than 2000 ppm.

Another process, called Multi-Stage Flash distillation, also produces freshwater, but requires more energy and is thus more expensive.

In arid regions like the Middle East, desalination is already essential, with 25 percent of the world's existing plants residing in Saudi Arabia alone. Record drought conditions in Australia have also moved desalination to the front burner in that country as municipalities scramble for answers.



A reverse osmosis membrane cartridge, left, and the actual exposed membrane, below.

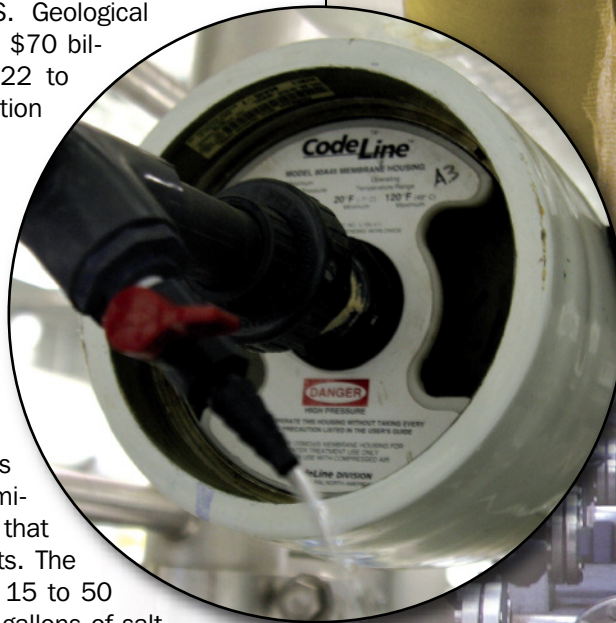

A valve can be opened to test the water in any of the reverse osmosis vessels.

There are more than 1,000 desalination plants in the United States, a majority residing in Florida, where the largest, Tampa Bay Seawater Desalination, produces 25 million gallons of drinking water per day (mgd), roughly 10 percent of what the area requires. Nationwide, however, desalination provides less than one percent of the country's freshwater.

In Southern California, for instance, water imported from the Colorado River and Northern California costs about \$500 per acre foot. (One acre foot is the amount of water necessary to cover one acre of land at a depth of one foot. It is the allotment of water used each year on average by every two or three American households, or about 326,000 gallons.) The cost of one acre foot of desalinated water can reach as much as \$1,200.

WHAT ARE THE DRAWBACKS?

For all of its potential good, desalination is littered with pitfalls that compromise its viability, not the least of which is expense.

A large industrial facility, likely a desalination plant, featuring rows of white reverse osmosis vessels. The vessels are arranged in a grid pattern, with multiple rows extending into the distance. The floor is a dark, gridded metal grate. The lighting is bright, highlighting the clean, white surfaces of the vessels.

At the Chino Basin 1 Desalter, four pumps, left, feed brackish groundwater into 168 reverse osmosis vessels, right, at a rate of 290-300 psi. Each pump and 42-vessel group works independently of the others. Each vessel contains seven reverse osmosis membranes.

Seawater Desalination – The Long Beach Method

The Long Beach Water Department has developed exciting new proprietary technology to convert seawater into high-quality drinking water in the most-cost effective manner. The Long Beach two-stage nanofiltration method is 20-30% more energy-efficient than traditional desalination methods, a major breakthrough that promises to significantly cut costs and make desalination a necessary element of creating more reliable water supplies for the future. In addition, the Long Beach Method includes two barriers, compared with only one for traditional desalination processes, thereby increasing reliability of water quality.

Here's how it works.

Energy Savings

Traditional desalination pushes seawater through a single membrane at pressures of approximately 1,000 pounds per square inch (psi). The Long Beach Method pushes seawater through Stage 1 at far less pressure (525 psi). The resulting water, about 40% of the original amount, is then pushed through Stage 2 at 250 PSI. The result: the Long Beach Method requires 20-30% less energy than traditional desalination. Both the Long Beach Method and traditional desalination require approximately 3 gallons of seawater to produce one gallon of potable water.

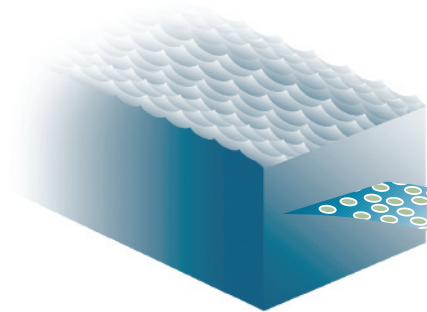

Seawater is filtered to remove suspended materials and is then pumped to Stage 1.

Stage 1: Filtered seawater is pumped under high pressure through nanofiltration membrane, which allows water molecules to pass but blocks all but the smallest 12% of salt molecules.

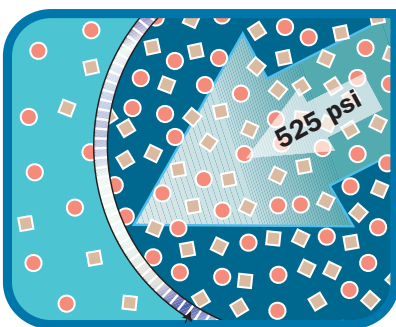

Stage 2: Water from Stage 1 – seawater with only smallest 12% of salt molecules – is pumped under lower pressure through second nanofiltration membrane, which blocks passage of almost all remaining salts.

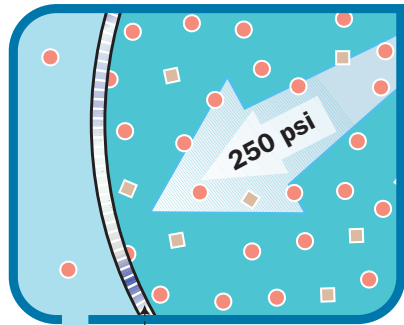

Nanofiltration membranes

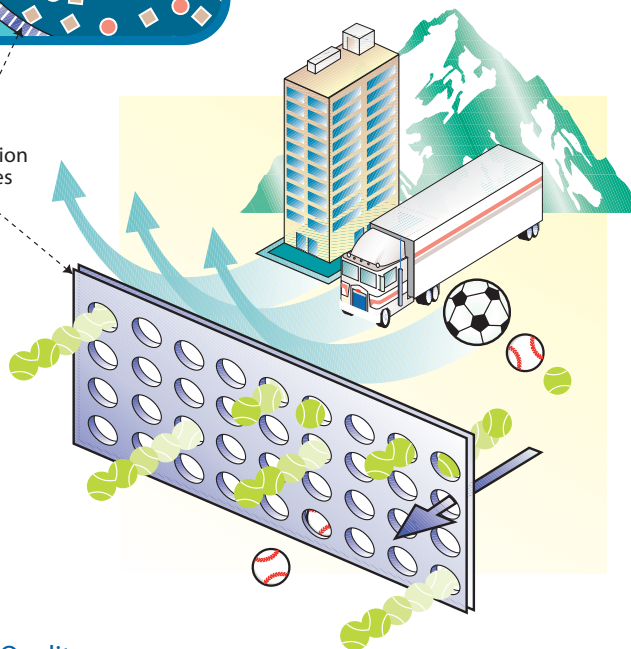

The process produces high-quality potable water that meets or betters all state and federal standards for safe drinking water. Long Beach Water Department has been operating a two-stage nanofiltration pilot plant since October 2001. A U.S. patent application for the technology is pending.

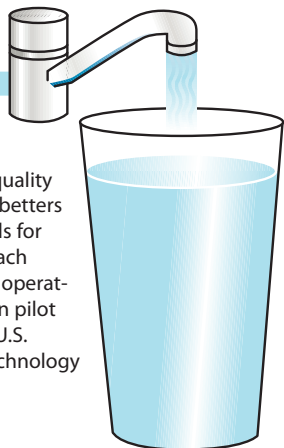

Water Quality

Nanofiltration membranes are made of semi-permeable material that allow almost nothing larger than pure water molecules to pass through. Because they are larger than water molecules, most salt molecules and other materials are left behind. In the above illustration, if water molecules are tennis balls, then salt molecules are soccer balls and softballs, viruses are trucks, bacteria are buildings and protozoa are mountains. The Long Beach Method includes two barriers, compared with only one for traditional desalination processes, thereby increasing reliability of water quality.

Long Beach Water Department working in partnership with the U.S. Bureau of Reclamation to advance desalination technology.
www.lbwater.org www.lc.usbr.gov/scao/



Long Beach Water's experimental research facility produces 300,000 gallons of fresh desalinated water each day.

According to Richard Atwater, general manager of the Inland Empire Utilities Agency (IEUA) in Southern California, pumping water from Northern California requires about 3,000 kWh per acre foot. Desalinating the same amount of seawater requires at least 4,000 kWh, a 25 percent increase.

“That’s going to be a tough hurdle for seawater desalination to overcome,” Atwater said. “But one of the great water clichés, by Ben Franklin, goes ‘You know the value of water when the well runs dry.’ If we can’t get any more water from the Colorado River or up north, all the other options become a lot more attractive.”

Seawater desalination is also not without negative environmental impacts. On top of the greenhouse gasses emitted by the engines that power the pumps, water intake and discharge represents a significant threat to fish eggs, plankton and other sea organisms near the plant, according to Tom Luster, an environmental scientist with the California Coastal Commission.

Open-ocean intake, which uses a long tube with a meshed screen at the opening, is indiscriminate in sucking up whatever small sea life might wind up in its path. Furthermore, brine, the byproduct of desalination, has a salinity rate of around 75,000 ppm. This discharge must be mixed with lower-salinity water before it can be safely returned to the ocean.

These concerns make it difficult for a desalination plant to even get built much less produce a significant source of freshwater.

“The entire process can cause a detrimental effect on marine biology,” Luster said. “And since desalination is very energy intensive, we want to determine what kind of contribution it makes to greenhouse gas emissions. How does it mitigate those?”

Long Beach Water is developing a protocol that might drastically limit the negative environmental impact while simultaneously reducing some of the costs of operation.



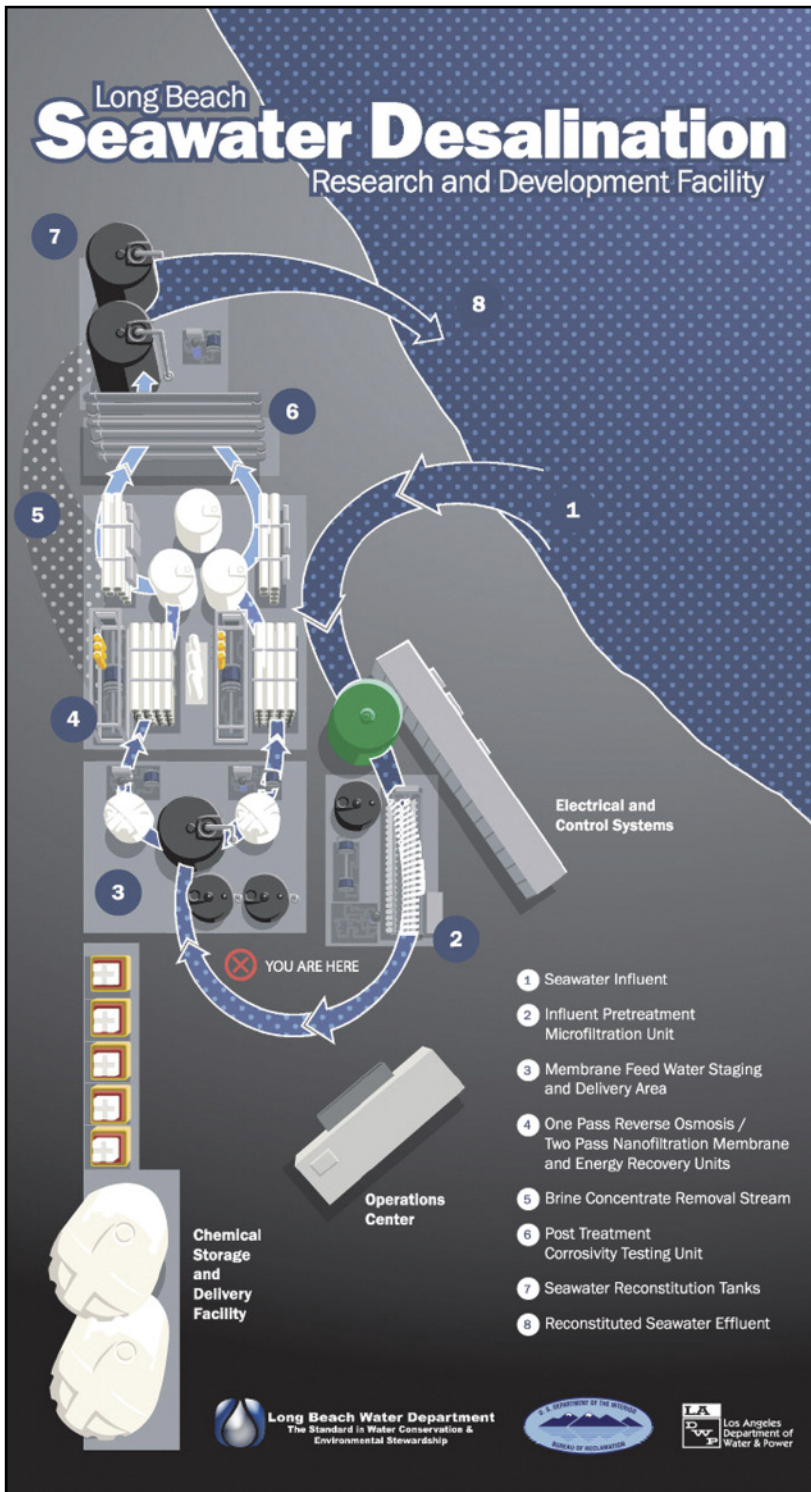

1. Seawater is drawn in from the Pacific Ocean to go through the desalination process.
2. Sand and other solids are filtered from the influent seawater.
3. Filtered water is prepared for entry into the reverse osmosis system.
4. Seawater undergoes two-stage reverse osmosis process to remove salts and other contaminants at the molecular level.
5. Brine, the high-salinity byproduct of reverse osmosis, is fed out of the filtration system.
6. Pure desalinated water is tested and treated to reduce its corrosivity. At this point it is ready to be added to the drinking water supply.
7. Brine is mixed with less saline water to make it suitable for return to the ocean.
8. Reconstituted seawater is pumped back into the Pacific Ocean.

The combination of a two-stage nanofiltration process, called the Long Beach Method, and the proposed Under Ocean Floor Seawater Intake and Discharge Demonstration System shows outstanding potential for increasing desalination's viability as a significant source of freshwater.

The Long Beach Method is 20-30 percent more energy-efficient than traditional desalination because it pushes the seawater through the membranes at nearly half the pressure (525 pounds per square inch (psi) as compared to the more typical 1,000 psi) during the first stage. The second stage is at 250 psi. Less pressure requires less energy, which means lower costs.

But even greater promise is seen in the intake and discharge system. By submerging the water collection and brine expulsion devices several feet under the sand, a great number of concerns are put to rest. The beach sand serves as a natural filter, greatly limiting potential harm to ocean organisms at both ends of the desalination process. In addition, this natural filtration decreases the amount of organic and suspended solids that make their way to the desalination plant.

"The amount of pre-treatment necessary before beginning the desalination filtering is reduced significantly," said Ryan Alsop, director of government and public affairs for Long Beach Water. "In fact, a desalination plant in Japan using this process has been able to completely bypass its pre-treatment facility."

Still, Alsop said desalination is a long way from being a cost-effective option for the City of Long Beach. Its 300,000-gallon-per-day research facility produces a mere drop in the bucket of what the community demands.

"It's a real challenge," he said of expanding the facility. "You have to build it, operate it, maintain it, not to mention get all of the permits necessary, which I believe there are 18-20. There's a path that needs to be established and at some point down the road, we'll make a go or no-go decision."

BRACKISH GROUNDWATER

Geography is another issue. As the price of transporting potable water further adds to its cost, seawater desalination's impact is mostly limited to coastal regions. For inland or high-elevation communities, this is not an option.

A potential solution to such geographic challenges, however, is the desalination of groundwater. Rather than filtering high-salinity seawater, this process draws water from brackish underground aquifers with a much lower salinity in the 600 to 2,000 ppm range. Such water sources are prevalent in, but not limited to, Southwest states such as California, Nevada, Arizona and Texas. The process could prove invaluable in New Mexico, where as much as 75 percent of groundwater is too saline for use without filtering, according to the USGS.

The Chino Desalter Authority (CDA), of which Atwater's IEUA is a part, operates two groundwater desalination plants

in California's Inland Empire. The pair produce 25 million gallons of pure drinking water per day, representing 20 percent of The City of Chino's supply and 15 percent of Norco's.

Because the brackish water is significantly less saline, Atwater says the Chino plants require only 1,500 kWh of electricity to produce one acre foot, 50 percent less than the cost of importing. The brackish water is forced through the reverse osmosis membrane at a relatively low pressure of 290-300 psi.

And Atwater claims the benefits are both immediate and sustained.

"We get to increase our drinking water supply and it allows us to more effectively manage the aquifers," he said. "If we hadn't built these plants, we would not have been able to bank as much water as we have from Northern California. If we have a drought now, that will prove big."

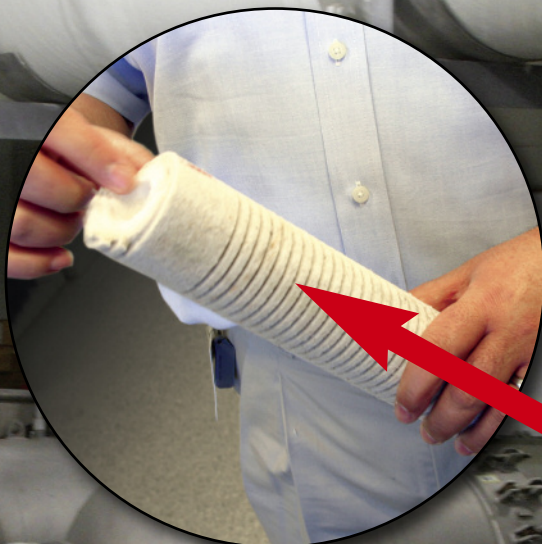

Before going through the reverse osmosis desalination process, brackish water at the Chino Basin 1 Desalter passes through a one-micron filter, each with about 120 cylinders, inset, to filter out solids such as sand and sediment.

CHINO BASIN 1 – DESALTER OVERVIEW

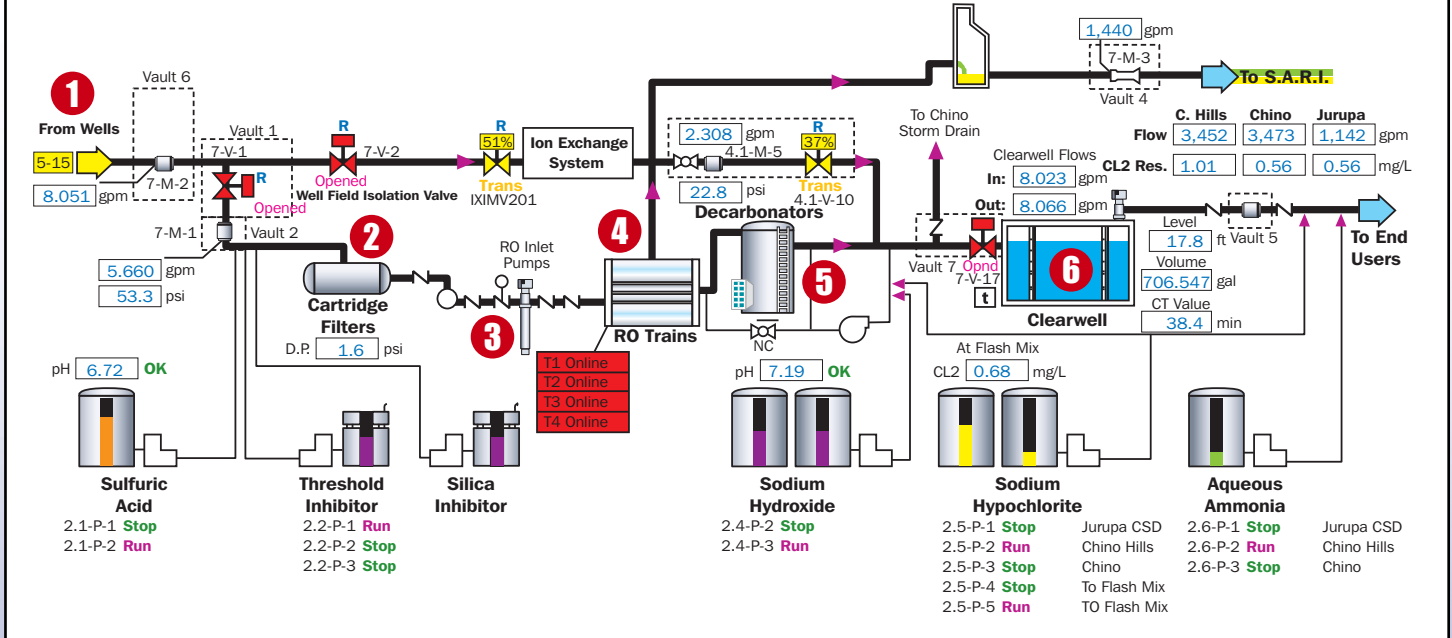

CHINO BASIN 1 DESALTER OVERVIEW: Brackish groundwater (1) from wells 5-15 is pumped to (2) the one-micron filters for sand and sediment filtration. From there, the water reaches (3) the 290-300 psi desalination pumps, which feed the (4) reverse osmosis vessels, which remove the salt molecules from the water. After desalination, the now freshwater is (5) decarbonated and treated (6) before being released to the end users.

Constructing the plants cost \$160 million in 2002 and the CDA is moving forward with a \$100 million expansion.

“In the past, the big challenge was always that it was more expensive than operating your local wells and dams, but now it’s much more cost effective,” Atwater said. “If we didn’t have statewide drought problems and the relative cost of imported water going up drastically, it wouldn’t be as necessary. But long term it’s still a smart thing to clean up the groundwater.”

importing water rises and desalination costs go down, there may someday be a meeting in the middle.

“Sometime in the next decade, we could see a situation where imported and desalinated water costs are comparable,” Alsop said. “Once you reach that point, the potential becomes more of a reality.”

Ultimately, the best option is typically going to remain that which is the least expensive. But as the cost of

Special thanks for the assistance of the following individuals, it was greatly appreciated: Sondra Elrod, IEUA; Richard Atwater, IEUA; Moustafa Aly, IEUA; Ryan Alsop, Long Beach Water; Tom Luster, California Coastal Commission.

The decarbonation and clearwell units at the Chino Basin 1 desalter facility.